

VACUUM RECEIVERS

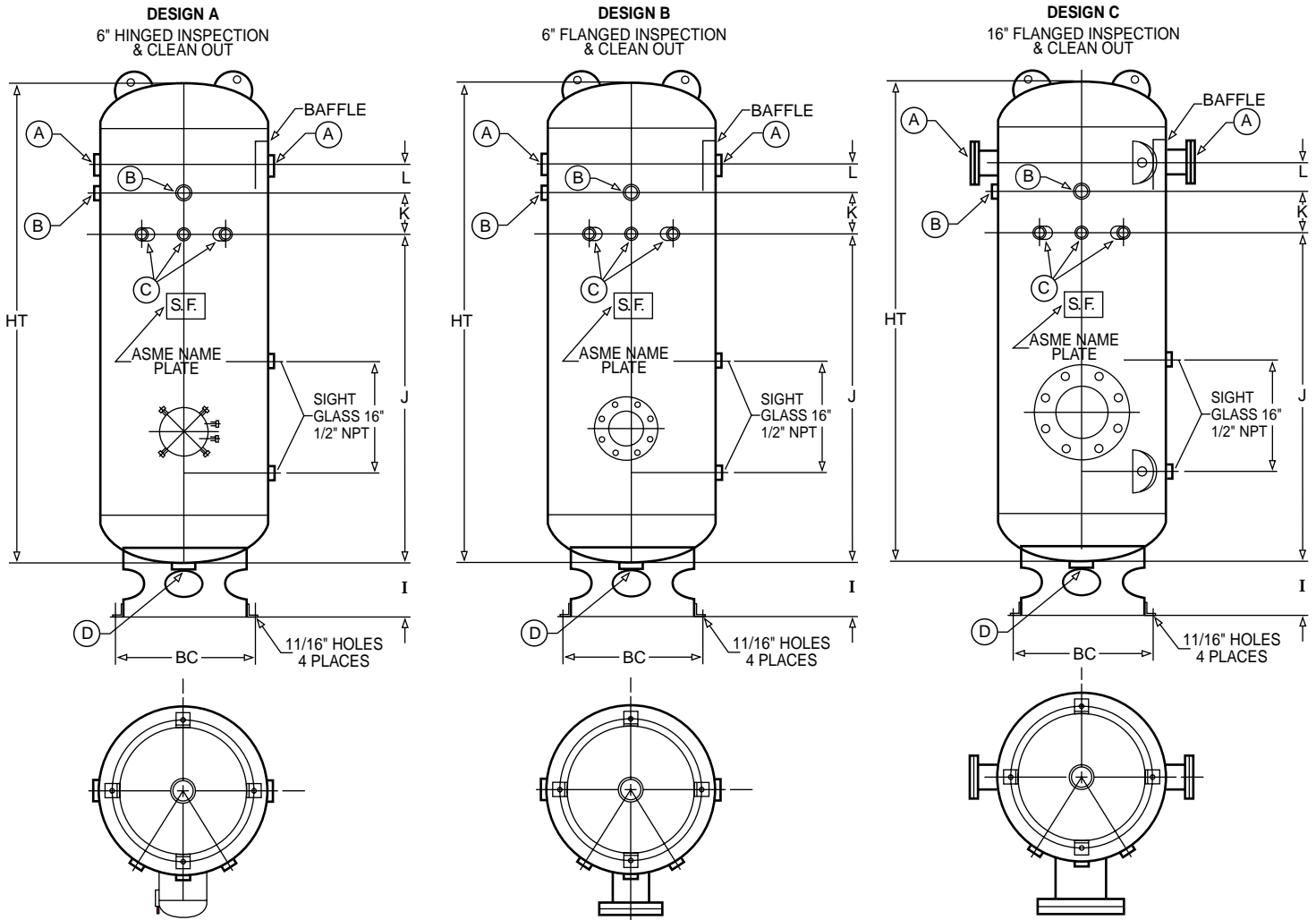

PART NUMBER					OPENINGS (NPT) "				DIMENSIONS "				
DESIGN A	DESIGN B	GAL	DIA	HT	A	B	C	D	I	J	K	L	BC
V10001*	V10011*	30	16	38	3	1	1/2	1-1/2	1-3/4	20	6	4	18-3/4
V10002*	V10012*	60	20	48	3	1	1/2	2	2-1/4	29	6	4	23-3/4
V10003	V10013	80	20	63	3	1	1/2	2	6	42	6	4	17
V10004	V10014	120	24	69	3	1	1/2	2	8	47	6	4	20
V10005	V10015	200	30	72	3	1	1/2	2	8	50	6	4	26
V10006	V10016	240	30	84	3	1	1/2	2	8	62	6	4	26
V10007	V10017	400	36	96	3	1	1/2	2	8	70	6	4	32
V10008	V10018	500	36	116	4	1	1/2	2	8	78	8	12	32

PART NUMBER					FLG	OPENINGS (NPT) "			DIMENSIONS "				
DESIGN C	GAL	DIA	HT	A	B	C	D	I	J	K	L	BC	
V10019	660	42	120	6	1	1/2	2	8	78	8	14	38	
V10020	1060	48	144	6	1	1/2	2	8	78	10	32	38	
V10021	1550	54	166	6	1	1/2	2	8	78	10	52	44	
V10022	2000	60	174	6	1	1/2	2	8	78	10	60	44	
V10023	2560	60	220	8	1	1/2	2	8	78	10	106	44	
V10024	3000	66	214	8	1	1/2	2	8	78	10	98	60	
V10025	3800	72	228	8	1	1/2	2	8	78	10	110	58	
V10026	4500	78	235	8	1	1/2	2	8	78	10	109	70	
V10027	5200	84	238	8	1	1/2	2	8	78	10	110	78	

- * These designs have 4 pressed steel feet.
- FLG = CL 150 Slip on flange (S.O.F.)
- 30 through 500 gallon vacuum receivers are available less clean out.